

## A. Current, Potential Difference and Resistance

1. Draw the circuit symbols for the following components...

- A switch open and a switch closed
- A cell
- A battery
- A diode
- A resistor
- A variable resistor
- An LED (light emitting diode)
- A lamp
- A fuse
- A voltmeter
- An ammeter
- A thermistor
- An LDR (light dependent resistor)

2. Describe the difference between a series circuit and a parallel circuit.

3. What is an electric current?

4. State the equation that links charge flow, current and time.

5. Calculate the current in a circuit if a charge of 4 C flows in 20 seconds.

6. In a lightning bolt, a charge of 15 C flows and there is a current of 30,000 A.

Calculate the duration of the lightning strike.

7. What is an ohmic conductor?

8. Which of the following current – potential difference graphs is for an ohmic conductor? Explain your answer.

A resistor at constant temperature

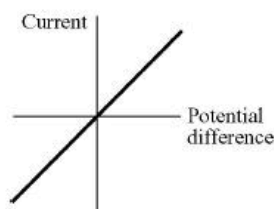

A filament lamp

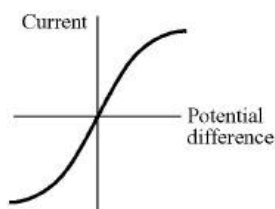

A diode

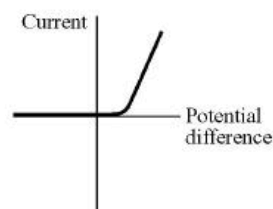

**9a.** A student wants to draw a current – potential difference graph for a filament lamp.

Draw a circuit that the student will need to set up to obtain the data needed to be able to draw the graph.

**9b** Sketch the current– potential difference graph the student should obtain and say why the graph has the shape you have drawn.

## B. Series and Parallel Circuits

- Describe how the currents in a series circuit and a parallel circuit differ.
- Draw a fully labelled series circuit that contains a switch, a battery and two lamps.
- Calculate the resistance of the resistors in series shown in the diagram below.

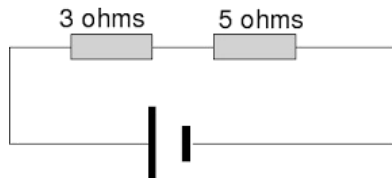

- Two resistors are placed in parallel as shown in the diagram below.

What will the maximum resistance of the circuit be?

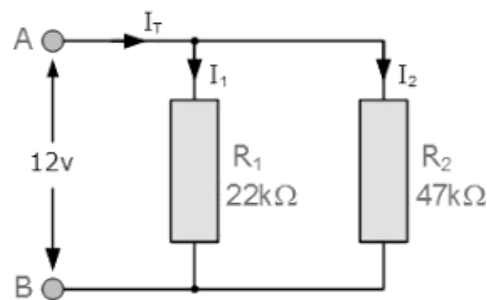

- What is the current in the main branch ( $I_s$ ) of the circuit shown?

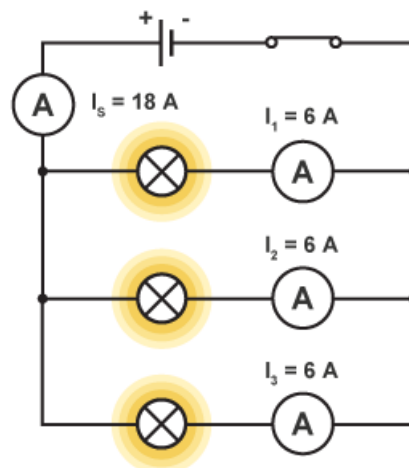

- The cell in the circuit above supplies a potential difference of 9 V to the circuit.

What is the potential difference across each lamp?  
Explain your answer.

## C. Domestic Uses and Safety

- What does a.c stand for?
- What does d.c stand for?
- Give an example of where a.c is used.

4. Give an example of where d.c is used.
5. Describe the difference between alternating potential difference and direct potential difference.  
You may draw a sketch graph to help answer the question.
6. What is the frequency and potential difference of mains electricity in the U.K?
7. Copy and complete the table below for the wire in three core electrical cable.

Name	Colour	Function

8. Explain why a live wire may be dangerous even when a switch in the mains circuit is open.

### D. Energy Transfers

1. State the equation that links power, potential difference and current. Include equation symbols and units.
2. State the equation that links power, current and resistance. Include equation symbols and units.
3. Recall the two equations for energy transferred. Include equation symbols and units.

4a) A kettle has a power rating of 1.2 kW.

The kettle runs on mains electricity at 230 V.

Calculate the current flowing through the kettle when in use.

4b) The kettle takes 1 minute and 20 seconds to boil some water.

Calculate the energy transferred by the kettle in this time.

5. Describe fully how electricity is transmitted from power stations to our homes.
6. Explain why a step-up transformer is used when transmitting electricity long distances across the UK.

**E. Static Electricity (PHYSICS ONLY)**

1. Draw the electric field pattern of a positively charged particle.
2. State the two types of electrical charge.
3. Describe what would happen if two like charged particles were placed near each other.
4. A balloon is rubbed on a jumper.
5. The balloon becomes positively charged.
6. Explain why the balloon gains a negative charge.
7. Describe what would happen if a charged rod was placed above a pile of dust.
8. What is an electric field?
9. Mike gets off a trampoline and gets an electric shock. Mike sees a spark pass between himself and the trampoline.
10. Explain why a spark formed in the air between Mike and the
11. trampoline.